

B180

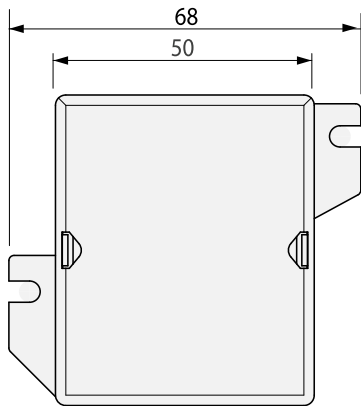

B 280 - 480

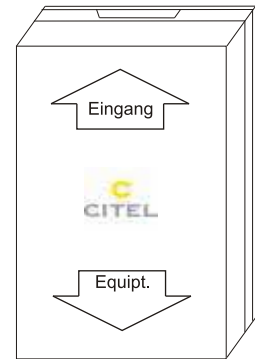

B180 Schaltbild

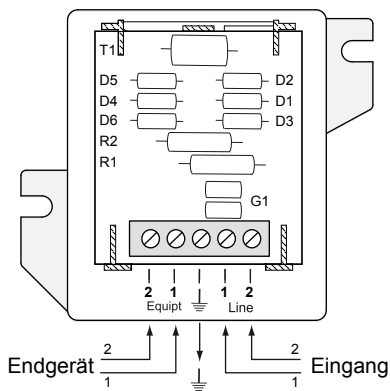

B 280 - B 480

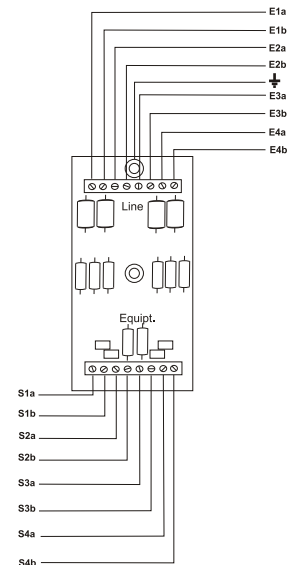

Typ	B180	B 280	B 380	B 480
I _L	300 mA	300 mA	300 mA	300 mA
U _{C DC}	8 V - 170 V	6 V - 110 V	6 V - 110 V	6 V - 110 V
U _{AC}	6 V - 121 V	7,1 V - 121,4 V	7,1 V - 121,4 V	7,1 V - 121,4 V
R				4,7 Ω
C				350 pF - 2500 pF (DBC < 25 pF)
θ _C				-40° bis +80°
max. □				1,5 mm ²
IP-Code				20

Fault Indication / Defektanzeige

Not / Keine

Remote Alarm Terminal / Fernmeldekontakt

Not / Keine

Anschlüsse B 180 - 480

